



SAGANA INSTRUMENTATION



**CLAPETS ANTI-RETOUR
CHECK VALVES
RÜCKSCHLAGVENTILE**

Description - Description - Beschreibung	4
Spécifications - Specifications - Spezifikationen	5
Différences visuelles - Visual differences - Unterscheidungsmerkmale	6
Connexions disponibles - Available connections - Verfügbare Anschlüsse	7

C1 - Clapet anti-retour - Check valve - Rückschlagventil	8
-----------------------------------------------------------------	---

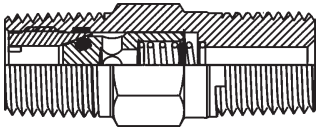

C2 - Clapet anti-retour réglable - Adjustable check valve - Regulierbares Rückschlagventil	10
---------------------------------------------------------------------------------------------------	----

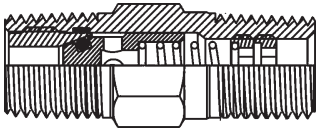

C3 - Clapet anti-retour - Check valve - Rückschlagventil	12
-----------------------------------------------------------------	----

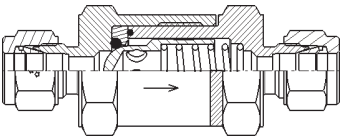

C4 - Clapet anti-retour réglable - Adjustable check valve - Regulierbares Rückschlagventil	17
---------------------------------------------------------------------------------------------------	----

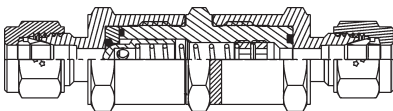

AT300 - Clapet anti-retour - Check valve - Rückschlagventil	20
--------------------------------------------------------------------	----

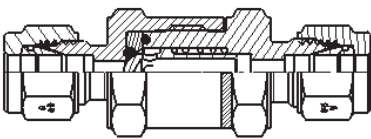

PG - Purge manuelle - Manual Purge - Entlüftungsventil	24
---------------------------------------------------------------	----

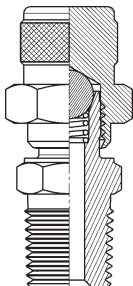

Données techniques - Technical data - Technische Daten	27
--------------------------------------------------------	----

C1	<p>Acier inoxydable 316L et laiton Pression de service max: 200 bar. Corps une pièce (compacte) Pression d'ouverture jusqu'à 50 psi Seulement avec raccord NPT.</p>	<p>SS 316L & Brass Working pressure up to 200 bar. One size body (compact) Cracking pressure up to 50 psi. NPT connections only.</p>	<p>Edelstahl 316L und Messing Max. Betriebsdruck 200 Bar Körper aus einem Stück gefertigt (kompakt) Öffnungsdruck bis 50 psi Nur mit NPT-Verbindungselement</p>	8
C2	<p>Acier inoxydable 316L et laiton Pression de service max: 200 bar. Corps une pièce (compacte) Pression d'ouverture réglable jusqu'à 350 psi. Seulement avec raccord NPT.</p>	<p>Brass & SS 316L Working pressure up to 200 bar. One size body (compact) Adjustable cracking pressure up to 350 psi NPT connections only</p>	<p>Edelstahl 316L und Messing Max. Betriebsdruck 200 Bar Körper aus einem Stück gefertigt (kompakt) Öffnungsdruck bis 350 psi einstellbar Nur mit NPT-Verbindungselement</p>	10
C3	<p>Acier inoxydable 316L et laiton Pression de service max: 300 bar. Pression différentielle max: 200 bar. Pression d'ouverture jusqu'à 100 psi. Large choix de raccords.</p>	<p>Brass & SS 316L Working pressure up to 300 bar. Maximale differential pressure: 200 bar. Cracking pressure up to 100 psi. Large choice of end connections.</p>	<p>Edelstahl 316L und Messing Max. Betriebsdruck 300 Bar Max. Differenzdruck 200 Bar Öffnungsdruck bis 100 psi Große Auswahl an Verbindungselementen</p>	12
C4	<p>Acier inoxydable 316L et laiton Pression de service max: 300 bar. Pression différentielle max: 200 bar. Pression d'ouverture réglable jusqu'à 350 psi. Large choix de raccords.</p>	<p>Brass & SS 316L Working pressure up to 300 bar. Maximale differential pressure: 200 bar. Adjustable cracking pressure up to 350 psi. Large choice of end connections.</p>	<p>Edelstahl 316L und Messing Max. Betriebsdruck 300 Bar Max. Differenzdruck 200 Bar Öffnungsdruck bis 350 psi einstellbar Große Auswahl an Verbindungselementen</p>	17
AT300	<p>Acier inoxydable 316L Pression de service max: 300 bar. Pression différentielle max: 300 bar. Pression d'ouverture jusqu'à 100 psi. Large choix de raccords.</p>	<p>SS 316L Working pressure up to 300 bar. Maximale differential pressure: 300 bar. Cracking pressure up to 100 psi. Large choice of end connections.</p>	<p>Edelstahl 316L Max. Betriebsdruck 300 Bar Max. Differenzdruck 300 Bar Öffnungsdruck bis 100 psi Große Auswahl an Verbindungselementen</p>	20

DESCRIPTION

Applications

Les clapets anti-retour SAGANA® permettent un contrôle unidirectionnel des liquides et des gaz. Ils sont utilisés dans des domaines variés tels que l'industrie, la pétrochimie, l'instrumentation, la recherche.

Caractéristiques

Les clapets anti-retour SAGANA® sont disponibles avec différents tarrages de ressorts:
Ressort fixe tarré pour une pression choisie.
Ressort à tarrage réglable.

Matériaux

Corps, clapet, écrou et bague en inox ou laiton (autres matières sur demande).
Joints toriques en VITON® (FPM) en standard (autres matières sur demande).
Ressort en acier inoxydable 302.
Joints toriques: FPM, NBR, EPDM, (PTFE)

Essais

Tous les clapets anti-retour sont testés à 100%.



ATTENTION

Respecter le sens d'écoulement du gaz indiqué par la flèche sur le corps du clapet.
Raccorder la tuyauterie amont et aval en veillant bien à la propreté des raccords.
Respecter les pressions maximales de service (PN).
Ne pas dévisser les raccords sous pression.

Viton®: marque déposée de Dupont

DESCRIPTION

Applications

SAGANA® check valves allow unidirectional control of liquids and gases. They are used in varied fields such as industry, petrochemicals, instrumentation and research.

Characteristics

SAGANA® check valves are available with different springs settings:
Fixed spring setting for a selected pressure.
Adjustable spring setting.

Materials

Body, valve, nut and ferrules in stainless steel or brass (other materials on request).
O-rings in VITON® (FPM) as standard (other materials on request).
Springs in Stainless Steel 302.
O-rings: FPM, NBR, EPDM, (PTFE)

Tests

All check valves are 100% leak tested.



CAUTION

Comply with the gas flow direction indicated by the arrow on the valve body.
Connect the upstream and downstream pipes taking care to ensure the cleanliness of the connectors.
Comply with the maximum service pressures (PN)
Do not loosen the connectors under pressure.

Viton®: is a Trade Mark of Dupont

BESCHREIBUNG

Einsatzbereiche

Die SAGANA® Rückschlagventile ermöglichen eine unidirektionelle Steuerung von Flüssigkeiten und Gasen.
Sie werden aus Sicherheitsgründen in vielfältigsten Bereichen eingesetzt, z.B. in der Industrie, der Petrochemie, der Instrumentierung und der Forschung.

Eigenschaften

Die SAGANA® Rückschlagventile sind mit verschiedenen Federstärken lieferbar:
Feste Feder, auf einen bestimmten Druck eingestellt.
Feder mit regulierbarer Stärke.

Werkstoffe

Ventilkörper, Mutter und Ring aus Edelstahl oder Messing (andere Werkstoffe auf Anfrage)
O-Ring-Dichtungen serienmäßig aus VITON® (FPM) (andere Werkstoffe auf Anfrage)
Feder aus Edelstahl 302.
O-Ring-Dichtungen: FPM, NBR, EPDM, (PTFE)

Test

Sämtliche Ventile werden zu 100% getestet.



VORSICHT

Beachten Sie die Durchflussrichtung des Gases, die durch den Pfeil auf dem Ventilkörper gekennzeichnet wird.
Schließen Sie die Rohre oberhalb und unterhalb des Ventils an, und achten Sie dabei sorgfältig auf die Sauberkeit der Verbindungen.

Viton®: Trade Mark von Dupont

SPECIFICATIONS
SPECIFICATIONS
SPEZIFIKATIONEN
Normes
Norms
Normen
Matériaux
Material
Werkstoffe

	Pièces décolletées turn parts Drehteile
Laiton	AFNOR CuZn40Pb3 ASTM B16 C36000 BS2874 CZ121 DIN 2.0401 EN 12164 CW614N
Brass	
Messing	
Acier Inoxydable	AFNOR Z6CND 17-12 AS ME S A479-316 BS 970 316-S 31 DIN 1.4404 E N 10088-1
Stainless Steel	
Edelstahl	

Caractéristiques
Characteristics
Eigenschaften

	Dimensions - Dimensions - Maße
mm :	3mm - 4mm - 6mm - 8mm - 10mm - 12mm - 14mm - 16mm - 18mm - 20mm - 22mm - 25 mm - ...
inch :	1/8" - 3/16" - 1/4" - 5/16" - 3/8" - 1/2" - 5/8" - 3/4" - 1" - ...
	Filets - Thread - Gewinde
Conical :	NPT (Briggs) - BSPT (Whitworth tapered) - ...
Parallel :	BSPP (Whitworth cylindrical) - NPSM - UN - SAE - ...
	Matière - Material - Werkstoffe
Standard :	Laiton - Acier inoxydable (AISI 316L), Brass - Stainless steel (316L), Messing - Edelsthal (316L)
Others :	Acier carbone - Carbon steel - Karbonat Edelsthal, Hastelloy®
	Options - Options - Optionen
	- Nickelé - Nickel plated - Vernickelt
	- dégraissé pour application oxygène - degreased for oxygen - entfettet für Sauerstoffanwendung
	- ...

DIFFÉRENCES VISUELLES

VISUAL DIFFERENCES

UNTERSCHIEDUNGSMERKMALE

Différences visuelles entre métrique / fractionnel

Les clapets anti-retour avec raccords à double bague pour tubes métriques sont livrés avec épaulements.

Visual differences between metric / inch

Check-valves manufactured with tube fittings for metric tubes are provided with shoulders.

Unterscheidungsmerkmale zwischen Metrisch / Zoll

Rückschlagventil für metrische Abmessungen sind mit Bund gefertigt.

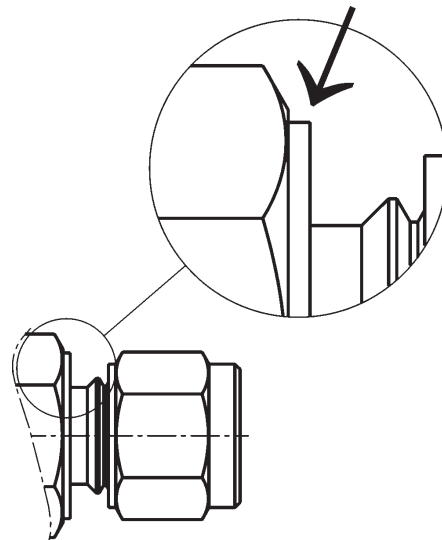

Différences visuelles entre filetage NPT / BSPT

Les clapets anti-retour avec filetage BSPT (mâle ou femelle) sont livrés avec épaulements

Visual differences between NPT / BSPT

Check-valves manufactured with BSPT thread are provided with shoulders

Optische Unterscheidung zwischen NPT / BSPT

Rückschlagventil für BSPT Gewinde sind mit Bund gefertigt

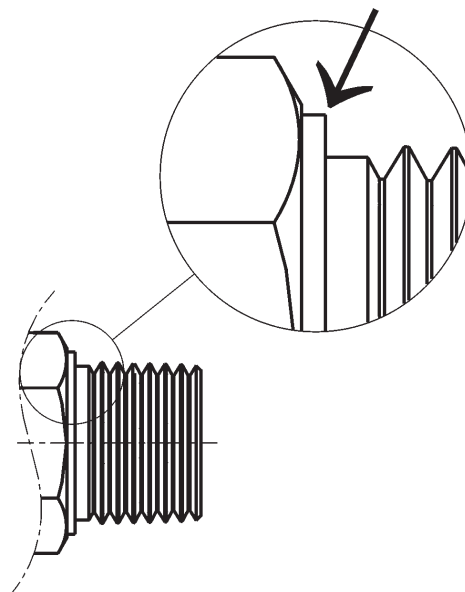

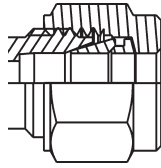

Sagana® Tube fittings						
Dim.	1/8"	1/4"	3/8"	1/2"	3/4"	1"
Ref.	2S	4S	6S	8S	12S	16S

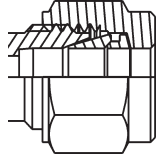

Sagana® Tube fittings								
Dim.	3mm	6mm	8mm	10mm	12mm	20mm	22mm	25mm
Ref.	M3S	M6S	M8S	M10S	M12S	M20S	M22S	M25S

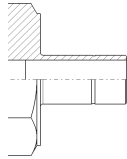

Sagana® Tube adapter						
Dim.	1/8"	1/4"	3/8"	1/2"	3/4"	1"
Ref.	2A	4A	6A	8A	12A	16A

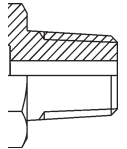

Male NPT						
Dim.	1/8"	1/4"	3/8"	1/2"	3/4"	1"
Ref.	2M	4M	6M	8M	12M	16M

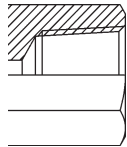

Femelle NPT						
Dim.	1/8"	1/4"	3/8"	1/2"	3/4"	1"
Ref.	2F	4F	6F	8F	12F	16F

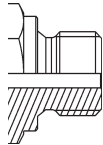

Male BSPP (RS)						
Dim.	1/8"	1/4"	3/8"	1/2"	3/4"	1"
Ref.	2MP	4MP	6MP	8MP	12MP	16MP

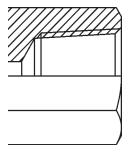

Femelle BSPP						
Dim.	1/8"	1/4"	3/8"	1/2"	3/4"	1"
Ref.	2FP	4FP	6FP	8FP	12FP	16FP

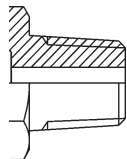

Male BSPT						
Dim.	1/8"	1/4"	3/8"	1/2"	3/4"	1"
Ref.	2MT	4MT	6MT	8MT	12MT	16MT

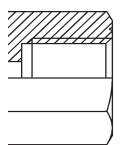

Female BSPT						
Dim.	1/8"	1/4"	3/8"	1/2"	3/4"	1"
Ref.	2FT	4FT	6FT	8FT	12FT	16FT

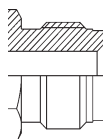

Male Gazel® (Face seal)				
Dim.	1/4"	3/8" or 1/2"	3/4"	1"
Ref.	4V	8V	12V	16V



Female Gazel® (Face seal)				
Dim.	1/4"	3/8" or 1/2"	3/4"	1"
Ref.	4FV	8FV	12FV	16FV

SERIES C1 - ONE PIECE -

DESCRIPTION

Les clapets anti-retour série «C1» ont un encombrement limité grâce à un corps usiné en une seule pièce. Le clapet «C1» est disponible seulement avec des raccords NPT. La pression maximale d'utilisation est de 200 bar. Différentes pressions d'ouverture sont disponibles.

DESCRIPTION

Series «C1» check valves have small volumes with use of a one piece machined body. Check valve «C1» is available only with NPT connectors. The maximum operating pressure is 200 bar. Different cracking pressures are available.

BESCHREIBUNG

Die Rückschlagventile der Baureihe «C1» weisen dank ihres aus einem Stück gearbeiteten Korpus einen geringen Raumbedarf auf. Das Ventil «C1» ist ausschließlich mit NPT-Verbindungen lieferbar. Der maximale Einsatzdruck beträgt 200 bar. Es sind verschiedene Öffnungsdrücke lieferbar.

INFORMATIONS TECHNIQUES

TECHNICAL DATA

TECHNISCHE DATEN

	Acier Inoxydable Stainless steel Edelstahl	Laiton Brass Messing
Pression de service max. Maximum working pressure Max Betriebsdruck	200 bar (2900 psi)	
Pression inverse max. Maximum back pressure Max. Gegendruck	200 bar (2900 psi)	
Température de service Temperature range Betriebstemperaturen	Voir le tableau "matière du joint" See the "Seal material" table Siehe die Tabelle "O-Ringwerkstoff"	
Pression d'ouverture Cracking pressure (psi) öffnungsdruck	1/3, 1, 3, 5, 10, 25, 40, 50	

Matière du joint Seal Material O-Ringwerkstoff	Ref.	Température de service Temperature rating Betriebstemperaturen
FPM (fluorocarbon Rubber)	FPM	-25°C to 200°C -13°F to 392°F
NBR Nitrile	NBR	-30°C to 120°C -22°F to 248°F
EPDM (ethylene Propylene Rubber)	EPDM	-50°C to 135°C -58°F to 275°F

NOMENCLATURE

PART LIST

NOMENKLATUR

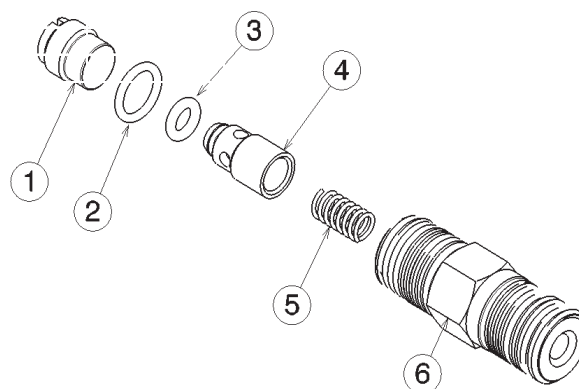

Item	Désignation	Designation	Beschreibung	Matière Material Werkstoff	
1	Siège	Seat	Sitz	AISI 316L	Brass
2	Joint torique	O-ring	O-ring	See table	/
3	Joint torique clapet	Poppet O-ring	O-ring Klappe	See table	/
4	Clapet	Poppet	Klappe	AISI 316L	Brass
5	Ressort	Spring	Feder	302	302
6	Corps	Body	Gehäuse	AISI 316L	Brass

SERIES C1 - ONE PIECE -

DIMENSIONS

DIMENSIONS

ABMESSUNGEN

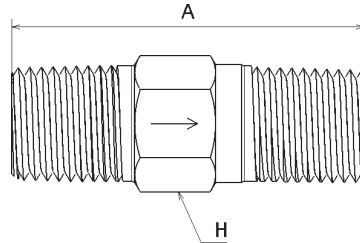

Part Number	Inlet - Outlet		A		H	
	Inlet	Outlet	mm	inch	mm	inch
4M - C1-*	1/4" Male NPT	1/4" Male NPT	41	1.61	14	0.55
4F - C1-*	1/4" Female NPT	1/4" Female NPT	47	1.85	19	0.75
4M 4F - C1-*	1/4" Male NPT	1/4" Female NPT	44	1.73	19	0.75
4F 4M - C1-*	1/4" Female NPT	1/4" Male NPT	44	1.73	19	0.75
8M - C1-*	1/2" Male NPT	1/2" Male NPT	65	2.56	22	0.87
8F - C1-*	1/2" Female NPT	1/2" Female NPT	75	2.95	27	1.06
8M 8F - C1-*	1/2" Male NPT	1/2" Female NPT	70	2.76	27	1.06
8F 8M - C1-*	1/2" Female NPT	1/2" Male NPT	70	2.76	27	1.06

COMMENT
COMMANDER

HOW TO ORDER

ZUM BESTELLEN

Example:

4F4M - C1 - 1 - SS - EPDM



Inlet connections	Outlet connections	Serie	Cracking pressure	Material	O-ring Material
① 4M 4F 8M 8F	② 4M-4F 8M-8F	③ C1	④ 1/3, 1, 3 5, 10, 25 40, 50	⑤ SS (Stainless steel) B (Brass)	⑥ FPM* NBR EPDM PTFE

* FPM is the standard, you don't have to specify it

SERIES C2 - ONE PIECE - ADJUSTABLE

DESCRIPTION

Les clapets anti-retour série «C2» ont un encombrement limité grâce à un corps usiné en une seule pièce. Le clapet «C2» est disponible seulement avec des raccords NPT. La pression maximale d'utilisation est de 200 bar. Différentes pressions d'ouverture sont disponibles par réglage manuel.

DESCRIPTION

Series «C2» check valves have small volumes by virtue of a one piece machined body. Valve C2 is available only with NPT connectors. The maximum operating pressure is 200 bar. Different cracking pressures are available by manual adjustment.

BESCHREIBUNG

Die Rückschlagventile der Baureihe „C2“ weisen dank ihres aus einem Stück gearbeiteten Korpus einen geringen Raumbedarf auf. Das Ventil C2 ist ausschließlich mit NPT-Verbindungen lieferbar. Der maximale Einsatzdruck beträgt 200 bar. Durch manuelle Regulierung können verschiedene Öffnungsdrücke erzielt werden.

INFORMATIONS TECHNIQUES

	Acier Inoxydable Stainless steel Edelstahl	Laiton Brass Messing
Pression de service max. Maximum working pressure Max Betriebsdruck	200 bar (2900 psi)	
Pression inverse max. Maximum back pressure Max. Gegendruck	200 bar (2900 psi)	
Température de service Temperature range Betriebstemperaturen	Voir le tableau "matière du joint" See the "Seal material" table Siehe die Tabelle "O-Ringwerkstoff"	
Pression d'ouverture Cracking pressure (psi) öffnungsdruck	3 to 50 psi 50 to 150 psi 150 to 350 psi	

TECHNICAL DATA

Matière du joint Seal Material O-Ringwerkstoff	Ref.	Température de service Temperature rating Betriebstemperaturen
FPM (fluorocarbon Rubber)	FPM	-25°C to 200°C -13°F to 392°F
NBR Nitrile	NBR	-30°C to 120°C -22°F to 248°F
EPDM (ethylene Propylene Rubber)	EPDM	-50°C to 135°C -58°F to 275°F

TECHNISCHE DATEN

NOMENCLATURE

PART LIST

NOMENKLATUR

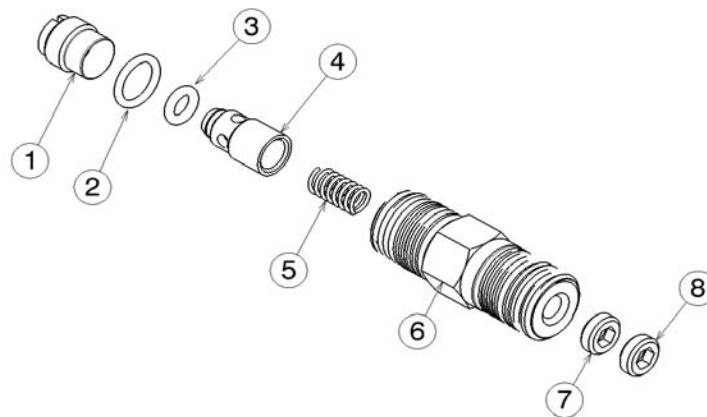

Item	Désignation	Designation	Beschreibung	Matière Material Werkstoff	
1	Siège	Seat	Sitz	AISI 316L	Brass
2	Joint torique	O-ring	O-ring	See table	/
3	Joint torique clapet	Poppet O-ring	O-ring Klappe	See table	/
4	Clapet	Poppet	Klappe	AISI 316L	Brass
5	Ressort	Spring	Feder	302	302
6	Corps	Body	Gehäuse	AISI 316L	Brass
7	Ecrou de réglage	Adjusting screw	Regulierschrauber	AISI 316L	Brass
8	Contre-écrou	Locking screw	Kontermutter	AISI 316L	Brass

SERIES C2 - ONE PIECE - ADJUSTABLE

DIMENSIONS

DIMENSIONS

ABMESSUNGEN

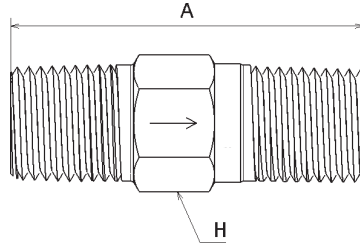

Part Number	Inlet - Outlet		A		H	
	Inlet	Outlet	mm	inch	mm	inch
4M -C2-*	1/4" Male NPT	1/4" Male NPT	41	1.61	14	0.55
4F -C2-*	1/4" Female NPT	1/4" Female NPT	47	1.85	19	0.75
4M 4F -C2-*	1/4" Male NPT	1/4" Female NPT	44	1.73	19	0.75
4F 4M -C2-*	1/4" Female NPT	1/4" Male NPT	44	1.73	19	0.75
8M -C2-*	1/2" Male NPT	1/2" Male NPT	65	2.56	22	0.87
8F -C2-*	1/2" Female NPT	1/2" Female NPT	75	2.95	27	1.06
8M 8F -C2-*	1/2" Male NPT	1/2" Female NPT	70	2.76	27	1.06
8F 8M -C2-*	1/2" Female NPT	1/2" Male NPT	70	2.76	27	1.06

COMMENT
COMMANDER

HOW TO ORDER

ZUM BESTELLEN

Example:

4M4F - C2 - 50 - SS - EPDM
 (1) (2) (3) (4) (5) (6)

Inlet connections	Outlet connections	Serie	Cracking pressure	Material	O-ring Material
(1) 4M 4F 8M 8F	(2) 4M 4F 8M 8F	(3) C2	(4) 3 (3 to 50) 50 (50 to 150) 150 (150 to 350)	(5) SS (Stainless steel) B (Brass)	(6) FPM* NBR EPDM PTFE

* FPM is the standard, you don't have to specify it

SERIES C3

DESCRIPTION

Les clapets anti-retour série «C3» sont disponibles avec différents raccords. La pression maximale d'utilisation est de 300 bar pour l'acier inoxydable
 Pression différentielle maximum: 200 bar.
 Différentes pressions d'ouverture sont disponibles.
 Une étiquette de couleur indique la pression d'ouverture.

DESCRIPTION

Series »C3« check valves are available with different connectors. The maximum operating pressure is 300 bar.
 Maximum differential pressure: 200bar
 Different cracking pressures are available.
 A coloured label indicates the opening pressure.

BESCHREIBUNG

Die Rückschlagventile der Baureihe «C3» sind mit verschiedenen Verbindungen lieferbar. Der maximale Einsatzdruck beträgt 300 bar.
 Maximaler Differenzialdruck: 200 bar
 Es sind verschiedene Öffnungsdrücke lieferbar. Der Öffnungsdruck wird durch ein farbiges Etikett angezeigt.

INFORMATIONS TECHNIQUES

	Acier Inoxydable Stainless steel Edelstahl	Laiton Brass Messing
Pression de service max. Maximum working pressure Max Betriebsdruck	300 bar (4351 psi)	200 bar (2900 psi)
Pression inverse max. Maximum back pressure Max. Gegendruck	300 bar (4351 psi)	200 bar (2900 psi)
Δ P Maximum	200 bar (2900 psi)	
Température de service Temperature range Betriebstemperaturen	Voir le tableau "matière du joint" See the "Seal material" table Siehe die Tabelle "O-Ringwerkstoff"	
Pression d'ouverture Cracking pressure öffnungsdruck	1/3, 1, 3	5, 10, 25 40, 50, 100

TECHNICAL DATA

Matière du joint Seal Material O-Ringwerkstoff	Ref.	Température de service Temperature rating Betriebstemperaturen
FPM (fluorocarbon Rubber)	FPM	-25°C to 200°C -13°F to 392°F
NBR Nitrile	NBR	-30°C to 120°C -22°F to 248°F
EPDM (ethylene Propylene Rubber)	EPDM	-50°C to 135°C -58°F to 275°F
PTFE* (Teflon)	PTFE	-40°C to 180°C -40°F to 356°F

*PTFE will not guaranty the tightness except when high back pressure is applied.

*PTFE ne garantit l'étanchéité qu'avec une contre-pression importante.

*PTFE garantiert die Dichtheit nur bei Hochdruck.

NOMENCLATURE

PART LIST

NOMENKLATUR

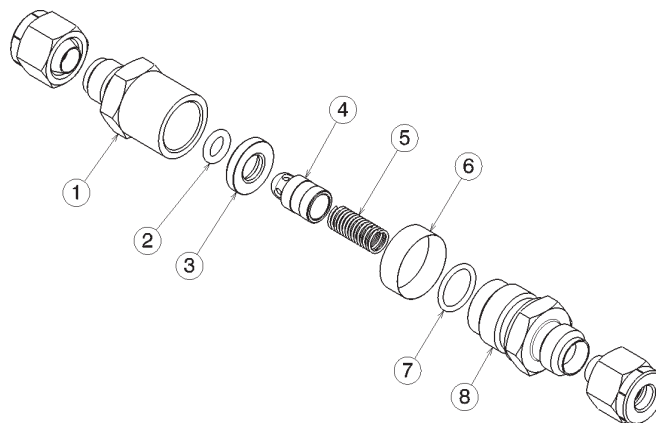

Item	Désignation	Designation	Beschreibung	Matière Material Werkstoff
1	Corps d'entrée	Inlet body	Eingangskörper	316L
2	Siège	Seat	Sitz	FPM*
3	Support de siège	Seat stand	Sitzräger	316L
4	Clapet	Valve	Klappe	316L
5	Ressort	Spring	Feder	302
6	Étiquette couleur	Colored label	Farbetikette	PP
7	O-ring	O-ring	O-ring	FPM*
8	Corps de sortie	Outlet body	Ausgangskörper	316 L

*For other materials, see the " Seal material" table .

SERIES C3

DIMENSIONS

DIMENSIONS

ABMESSUNGEN

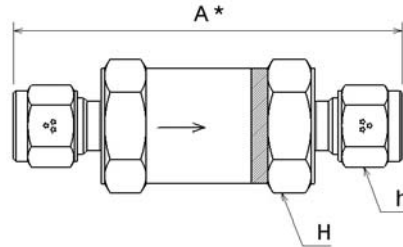

Dimensions are measured with nuts in the finger tight position.

Part Number	CONNECTIONS		Orifice size		A *		H		h	
	Inlet	Outlet	mm	inch	mm	inch	mm	inch	mm	inch
2S-C3-*	1/8" Tube fittings	1/8" Tube fittings	2.4	0.09	57.5	2.26	19	0.75	12	0.47
2A-C3-*	1/8" Tube adapter	1/8" Tube adapter	2	0.08	54.0	2.13	19	0.75		
2M-C3-*	1/8" Male NPT	1/8" Male NPT	3.2	0.13	46.0	1.81	19	0.75		
2F-C3-*	1/8" Female NPT	1/8" Female NPT	3.2	0.13	46.0	1.81	19	0.75		
2M 2F-C3-*	1/8" Male NPT	1/8" Female NPT	3.2	0.13	46.0	1.81	19	0.75		
2F 2M-C3-*	1/8" Female NPT	1/8" Male NPT	3.2	0.13	46.0	1.81	19	0.75		
2M P-C3-*	1/8" Male BSPP	1/8" Male BSPP	3.2	0.13	46.0	1.81	19	0.75		
2F P-C3-*	1/8" Female BSPP	1/8" Female BSPP	3.2	0.13	46.0	1.81	19	0.75		
2M T-C3-*	1/8" Male BSPT	1/8" Male BSPT	3.2	0.13	46.0	1.81	19	0.75		
2F T-C3-*	1/8" Female BSPT	1/8" Female BSPT	3.2	0.13	46.0	1.81	19	0.75		
M 3S-C3-*	3mm Tube fittings	3mm Tube fittings	2.2	0.09	58.9	2.32	19	0.75	12	0.47

Part Number	CONNECTIONS		Orifice size		A *		H		h	
	Inlet	Outlet	mm	inch	mm	inch	mm	inch	mm	inch
4S-C3-*	1/4" Tube fittings	1/4" Tube fittings	4.5	0.18	62.5	2.46	19	0.75	14	0.55
4A-C3-*	1/4" Tube adapter	1/4" Tube adapter	4.5	0.18	58.6	2.31	19	0.75		
4M-C3-*	1/4" Male NPT	1/4" Male NPT	4.5	0.18	56.5	2.22	19	0.75		
4F-C3-*	1/4" Female NPT	1/4" Female NPT	4.5	0.18	58.5	2.30	19	0.75		
4M 4F-C3-*	1/4" Male NPT	1/4" Female NPT	4.5	0.18	57.5	2.26	19	0.75		
4F 4M-C3-*	1/4" Female NPT	1/4" Male NPT	4.5	0.18	57.5	2.26	19	0.75		
4M 4S-C3-*	1/4" Male NPT	1/4" Sagalok	4.5	0.18	60	2.36	19	0.75		
4M P-C3-*	1/4" Male BSPP	1/4" Male BSPP	4.5	0.18	54	2.13	19	0.75		
4F P-C3-*	1/4" Female BSPP	1/4" Female BSPP	4.5	0.18	47	1.85	19	0.75		
4M T-C3-*	1/4" Male BSPT	1/4" Male BSPT	4.5	0.18	56.5	2.22	19	0.75		
4F T-C3-*	1/4" Female BSPT	1/4" Female BSPT	4.5	0.18	58	2.28	19	0.75		
4V-C3-*	1/4" Male Gazel®	1/4" Male Gazel®	4.5	0.18	58	2.28	19	0.75		
M 6S-C3-*	6mm Tube fittings	6mm Tube fittings	4	0.16	61.8	2.43	19	0.75	14	0.55

SERIES C3

Part Number	CONNECTIONS		Orifice size		A *		H		h	
	Inlet	Outlet	mm	inch	mm	inch	mm	inch	mm	inch
6S-C3-*	3/8" Tube fittings	3/8" Tube fittings	7.1	0.28	83	3.27	26	102	19	0.75
6A-C3-*	3/8" Tube adapter	3/8" Tube adapter	7.1	0.28	78.5	3.09	26	102		
6M-C3-*	3/8" Male NPT	3/8" Male NPT	9.1	0.36	72.2	2.84	26	102		
6F-C3-*	3/8" Female NPT	3/8" Female NPT	9.1	0.36	72.2	2.84	26	102		
6M 6F-C3-*	3/8" Male NPT	3/8" Female NPT	9.1	0.36	72.2	2.84	26	102		
6F 6M-C3-*	3/8" Female NPT	3/8" Male NPT	9.1	0.36	72.2	2.84	26	102		
6M 6S-C3-*	3/8" Male NPT	3/8" Tube fittings	7.1	0.28	77.5	3.05	26	102		
6M 8S-C3-*	3/8" Male NPT	1/2" Tube fittings	9.1	0.36	80	3.15	26	102		
6M P-C3-*	3/8" Male BSPP	3/8" Male BSPP	9.1	0.36	66	2.60	26	102		
6F P-C3-*	3/8" Female BSPP	3/8" Female BSPP	9.1	0.36	67.6	2.66	26	102		
6M T-C3-*	3/8" Male BSPT	3/8" Male BSPT	9.1	0.36	72.2	2.84	26	102		
6F T-C3-*	3/8" Female BSPT	3/8" Female BSPT	9.1	0.36	72.2	2.84	26	102		
M 8S-C3-*	8mm Tube fittings	8mm Tube fittings	6.4	0.25	82.2	3.24	26	102	17	0.67
M 10S-C3-*	10mm Tube fittings	10mm Tube fittings	7.9	0.31	84	3.31	26	102	19	0.75

Part Number	CONNECTIONS		Orifice size		A *		H		h	
	Inlet	Outlet	mm	inch	mm	inch	mm	inch	mm	inch
8S-C3-*	1/2" Tube fittings	1/2" Tube fittings	10	0.39	92	3.62	32	126	22	0.87
8A-C3-*	1/2" Tube adapter	1/2" Tube adapter	10	0.39	94	3.70	32	126		
8M-C3-*	1/2" Male NPT	1/2" Male NPT	10	0.39	86	3.39	32	126		
8F-C3-*	1/2" Female NPT	1/2" Female NPT	10	0.39	87	3.43	32	126		
8M 8F-C3-*	1/2" Male NPT	1/2" Female NPT	10	0.39	86	3.39	32	126		
8F 8M-C3-*	1/2" Female NPT	1/2" Male NPT	10	0.39	86	3.39	32	126		
8M 8S-C3-*	1/2" Male NPT	1/2" Tube fittings	10	0.39	88.8	3.50	32	126		
8M P-C3-*	1/2" Male BSPP	1/2" Male BSPP	10	0.39	76.3	3.00	32	126		
8F P-C3-*	1/2" Female BSPP	1/2" Female BSPP	10	0.39	97.5	3.84	32	126		
8M T-C3-*	1/2" Male BSPT	1/2" Male BSPT	10	0.39	86	3.39	32	126		
8F T-C3-*	1/2" Female BSPT	1/2" Female BSPT	10	0.39	86	3.39	32	126		
8V-C3-*	1/2" Male Gazel®	1/2" Male Gazel®	10	0.39	89	3.50	32	126		
M 12S-C3-*	12mm Tube fittings	12mm Tube fittings	9.5	0.37	92	3.62	32	126	22	0.87

Part Number	CONNECTIONS		Orifice size		A *		H		h	
	Inlet	Outlet	mm	inch	mm	inch	mm	inch	mm	inch
12S-C3-*	3/4" Tube fittings	3/4" Tube fittings	15.1	0.59	104	4.09	36	142	30	1.18
12A-C3-*	3/4" Tube adapter	3/4" Tube adapter	15.1	0.59	109	4.29	36	142		
12M-C3-*	3/4" Male NPT	3/4" Male NPT	15.1	0.59	95	3.74	36	142		
12F-C3-*	3/4" Female NPT	3/4" Female NPT	15.1	0.59	95	3.74	36	142		
12M 12F-C3-*	3/4" Male NPT	3/4" Female NPT	15.1	0.59	95	3.74	36	142		
12F 12M-C3-*	3/4" Female NPT	3/4" Male NPT	15.1	0.59	95	3.74	36	142		
12M 12S-C3-*	3/4" Male NPT	3/4" Tube fittings	15.1	0.59	101	3.98	36	142		
12M P-C3-*	3/4" Male BSPP	3/4" Male BSPP	15.1	0.59	96.3	3.79	36	142		
12F P-C3-*	3/4" Female BSPP	3/4" Female BSPP	15.1	0.59	89	3.50	36	142		
12M T-C3-*	3/4" Male BSPT	3/4" Male BSPT	15.1	0.59	98	3.86	36	142		
12F T-C3-*	3/4" Female BSPT	3/4" Female BSPT	15.1	0.59	98	3.86	36	142		
12V-C3-*	3/4" Male Gazel®	3/4" Male Gazel®	15.1	0.59	110.5	4.35	36	142		
M 20S-C3-*	20mm Tube fittings	20mm Tube fittings	15.1	0.59	105	4.13	36	142	32	1.26
M 22S-C3-*	22mm Tube fittings	22mm Tube fittings	15.1	0.59	105	4.13	36	142	32	1.26

SERIES C3

Part Number	CONNECTIONS		Orifice size		A*		H		h	
	Inlet	Outlet	mm	inch	mm	inch	mm	inch	mm	inch
16S-C3-*	1" Tube fittings	1" Tube fittings	16.7	0.66	117	4.61	42	165	38	150
16A-C3-*	1" Tube adapter	1" Tube adapter	16.7	0.66	119	4.69	42	165		
16M-C3-*	1" Male NPT	1" Male NPT	16.7	0.66	103	4.06	42	165		
16F-C3-*	1" Female NPT	1" Female NPT	16.7	0.66	103	4.06	42	165		
16M 16F-C3-*	1" Male NPT	1" Female NPT	16.7	0.66	103	4.06	42	165		
16F 16M-C3-*	1" Female NPT	1" Male NPT	16.7	0.66	103	4.06	42	165		
16M 16S-C3-*	1" Male NPT	1" Tube fittings	16.7	0.66	110	4.33	42	165		
16M P-C32-*	1" Male BSPP	1" Male BSPP	16.7	0.66	98	3.86	42	165		
16F P-C3-*	1" Female BSPP	1" Female BSPP	16.7	0.66	103	4.06	42	165		
16M T-C3-*	1" Male BSPT	1" Male BSPT	16.7	0.66	103	4.06	42	165		
16F T-C3-*	1" Female BSPT	1" Female BSPT	16.7	0.66	103	4.06	42	165		
16V-C3-*	1" Male Gazel®	1" Male Gazel®	16.7	0.66	106	4.17	42	165		
M 25S-C3-*	25mm Tube fittings	25mm Tube fittings	16.7	0.66	119	4.69	42	165	25	0.98

COMMENT
COMMANDER

HOW TO ORDER

ZUM BESTELLEN

Example:

8S - 8M - C3 - 3 - SS - NBR

① ② ③ ④ ⑤ ⑥

Inlet connections	Outlet connections	Serie	Cracking pressure	Material	O-ring Material
① 2S - 2A-2M-2F-2MP 2FP-2MT-2FT-M3	② 2S - 2A-2M-2F-2MP 2FP-2MT-2FT-M3	③ C3	④ 1/3	⑤ SS (Stainless steel)	⑥ FPM*
4S-4A-4M-4F-4MP 4FP-4MT-4FT-4V-M6	4S-4A-4M-4F-4MP 4FP-4MT-4FT-4V-M6		1		
6S-6A-6M-6F-6MP-M10 6FP-6MT-6FT-M8	6S-6A-6M-6F-6MP-M10 6FP-6MT-6FT-M8		2		
8S-8A-8M-8F-8MP 8FP-8MT-8FT-8V-M12	8S-8A-8M-8F-8MP 8FP-8MT-8FT-8V-M12		3		
12S-12A-12M-12F-12MP-M22 12FP-12MT-12FT-12V-M20	12S-12A-12M-12F-12MP-M22 12FP-12MT-12FT-12V-M20		4		
16S-16A-16M-16F-16MP 16FP-16MT-16FT-16V-M25	16S-16A-16M-16F-16MP 16FP-16MT-16FT-16V-M25		10		
			25		
			40		
			50		
			100		
				B (Brass)	EPDM
					PTFE

* FPM is the standard, you don't have to specify it

SERIES C3

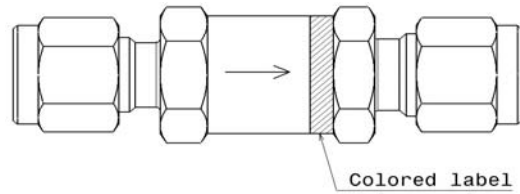

Cracking Pressure	Label Color		
1/3 psi	Blanc	White	Weiß
1 psi	Gris	Grey	Grau
2 psi	Jaune	Yellow	Gelb
3 psi	Orange	Orange	Orange
4 psi	Rose	Pink	Rosa
10 psi	Rouge	Red	Rot
25 psi	Brun	Brown	Braun
40 psi	Vert	Green	Grün
50 psi	Bleu	Blue	Blau
100 psi	Noir	Black	Schwartz

SERIES C4 - ADJUSTABLE

DESCRIPTION

Les clapets anti-retour série «C4» sont disponibles avec différents raccords. La pression maximale d'utilisation est de 300 bar pour l'acier inoxydable. Pression différentielle maximum: 200 bar. Différentes pressions d'ouverture sont disponibles par réglage manuel. Une étiquette de couleur indique la pression d'ouverture.

DESCRIPTION

Series «C4» check valves are available with different connectors. The maximum operating pressure for stainless steel is 300 bar. Maximum differential pressure: 200bar. Different cracking pressures are available by manual adjustment. A coloured label indicates the opening pressure.

BESCHREIBUNG

Die Rückschlagventile der Baureihe «C4» sind mit verschiedenen Verbindungen lieferbar. Der maximale Einsatzdruck beträgt 300 bar bei Edelstahl. Maximaler Differenzialdruck 200bar. Durch manuelle Regulierung können verschiedene Öffnungsdrücke erzielt werden. Der Öffnungsdruck wird durch ein farbiges Etikett angezeigt.

INFORMATIONS TECHNIQUES

	Acier Inoxydable Stainless steel Edelstahl	Laiton Brass Messing
Pression de service max. Maximum working pressure Max. Betriebsdruck	300 bar (4351 psi)	200 bar (2900 psi)
Pression inverse max. Maximum back pressure Max. Gegendruck	300 bar (4351 psi)	200 bar (2900 psi)
ΔP Maximum	200 bar (2900 psi)	
Température de service Temperature range Betriebstemperaturen	Voir le tableau "matière du joint" See the "Seal material" table Siehe die Tabelle "O-Ringwerkstoff"	
Pression d'ouverture Cracking pressure öffnungsdruck	3 to 50 psi 50 to 150 psi 150 to 350 psi	

TECHNICAL DATA

Matière du joint Seal Material O-Ringwerkstoff	Ref.	Température de service Temperature rating Betriebstemperaturen
FPM (fluorocarbon Rubber)	FPM	-25°C to 200°C -13°F to 392°F
NBR Nitrile	NBR	-30°C to 120°C -22°F to 248°F
EPDM (ethylene Propylene Rubber)	EPDM	-50°C to 135°C -58°F to 275°F
PTFE* (Teflon)	PTFE	-40°C to 180°C -40°F to 356°F

*PTFE will not guaranty the tightness except when high back pressure is applied.

*PTFE ne garantit l'étanchéité qu'avec une contre-pression importante.

*PTFE garantiert die Dichtheit nur bei Hochdruck.

NOMENCLATURE

PART LIST

NOMENKLATUR

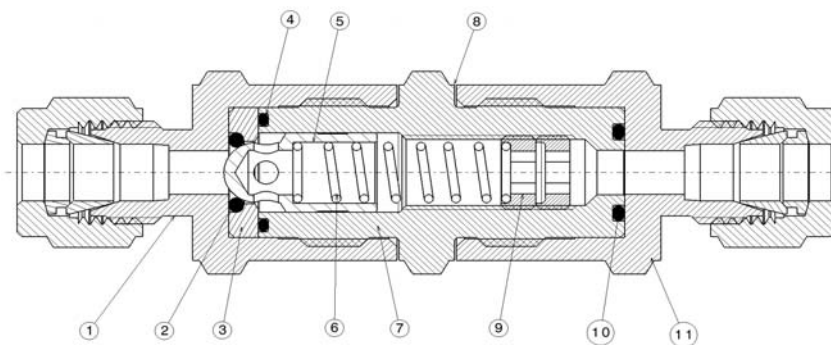

Item	Désignation	Designation	Beschreibung	Matière Material Werkstoff	
1	Corps d'entrée	Inlet Body	Eingangskörper	AISI 316L	Brass
2	Siège O-ring	Seat	Sitz	FPM*	FPM*
3	Support siège	Seat stand	Sitzträger	AISI 316L	Brass
4	Joint torique	O-ring	O-ring	FPM*	FPM*
5	Clapet	Poppet	Klappe	AISI 316L	Brass
6	Ressort	Spring	Feder	302	302
7	Corps central	Center body	Central Body	AISI 316L	Brass
8	Étiquette couleur	Colored label	Farbetikette	PP	PP
9	Ecrou de réglage	Adjusting screw	Adjusting nut	AISI 316L	Brass
10	Joint torique	O-ring	O-ring	FPM*	FPM*
11	Corps de sortie	Outlet body	Ausgangskörper	AISI 316L	Brass

*For other materials, see the " Seal material " table.

SERIES C4 - ADJUSTABLE

DIMENSIONS

DIMENSIONS

ABMESSUNGEN

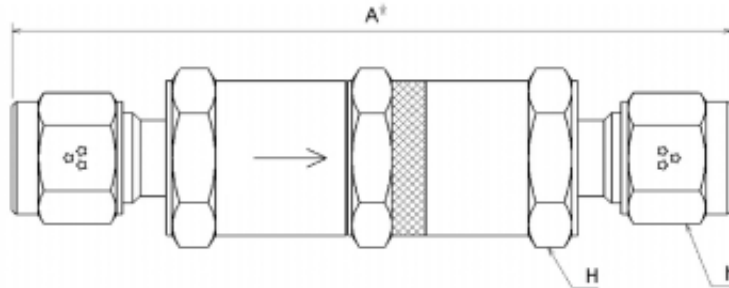

* Dimensions are measured with nuts in the finger tight position.

Part Number	Inlet - Outlet		Orifice size		A *		H		h	
	Inlet	Outlet	mm	inch	mm	inch	mm	inch	mm	inch
4S-C4-*	1/4" Tube fittings	1/4" Tube fittings	4.5	0.18	81	3.19	19	0.75	14	0.55
M 6S-C4-*	6mm Tube fittings	6mm Tube fittings	4.5	0.18	82	3.23	19	0.75	14	0.55
4M -C4-*	1/4" Male NPT	1/4" Male NPT	4.5	0.18	74	2.91	19	0.75		
4M 4S-C4-*	1/4" Male NPT	1/4" Tube fittings	4.5	0.18	77	3.03	19	0.75		
4V-C4-*	1/4" Male Gazel®	1/4" Male Gazel®	4.5	0.18	76.6	3.02	19	0.75		
M 8S-C4-*	8mm Tube fittings	8mm Tube fittings	6.4	0.25	110.7	4.36	26	102	17	0.67

COMMENT
COMMANDER

HOW TO ORDER

ZUM BESTELLEN

Example:

4S - M6 - C4 - 50 - SS - EPDM

① ② ③ ④ ⑤ ⑥

4M - C4 - 3 - B

① ② ③ ④

Inlet connections	Outlet connections	Serie	Cracking pressure	Material	O-ring Material
① 4S-M6-4M-4V M8	② 4S-M6-4M-4V M8	③ C4	④ 3 (from 3 to 50 psi) 50 (from 50 to 150 psi) 150 (from 150 to 300 psi)	⑤ SS (Stainless steel) B (Brass)	⑥ FPM* NBR EPDM PTFE

* FPM is the standard, you don't have to specify it

SERIES C4 - ADJUSTABLE

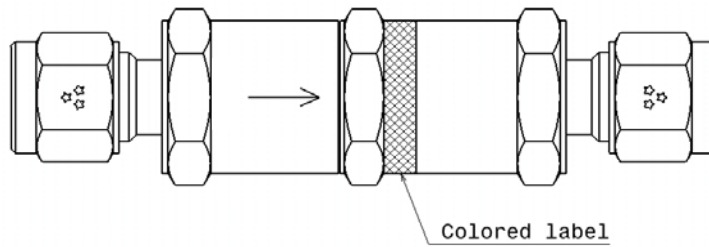

Cracking Pressure	Label Color
From 3 to 50 psi	White
From 50 to 150 psi	Blue
From 150 to 350 psi	Red

SERIES AT300 - HIGH PRESSURE

DESCRIPTION

Les clapets anti-retour AT-300 sont disponibles avec différents raccords. La pression maximale d'utilisation est de 300 bar. Différentes pressions d'ouverture sont disponibles. Une étiquette de couleur indique la pression d'ouverture. Homologation R110

DESCRIPTION

Check valves AT300 are available with different connectors. The maximum operating pressure for stainless steel is 300 bar. Different cracking pressures are available. A coloured label indicates the opening pressure. Homologation R110

BESCHREIBUNG

Das Rückschlagventil AT-300 ist mit verschiedenen Verbindungen lieferbar. Der maximale Einsatzdruck beträgt 300 bar bei Edelstahl. Es sind verschiedene Öffnungsdrücke lieferbar. Der Öffnungsdruck wird durch ein farbiges Etikett angezeigt. Homologation R110

INFORMATIONS TECHNIQUES

TECHNICAL DATA

TECHNISCHE DATEN

Matière du joint Seal Material O-Ringwerkstoff	Ref.	Température de service Temperature rating Betriebsstemperaturen
FPM (fluorocarbon Rubber)	FPM	-25°C to 200°C -13°F to 392°F
NBR Nitrile	NBR	-30°C to 120°C -22°F to 248°F
EPDM (ethylene Propylene Rubber)	EPDM	-50°C to 135°C -58°F to 275°F
PTFE* (Teflon)	PTFE	-40°C to 180°C -40°F to 356°F

*PTFE will not guaranty the tightness except when high back pressure is applied.
*PTFE ne garantit l'étanchéité qu'avec une contre-pression importante.
*PTFE garantiert die Dichtheit nur bei Hochdruck.

NOMENCLATURE

PART LIST

NOMENKLATUR

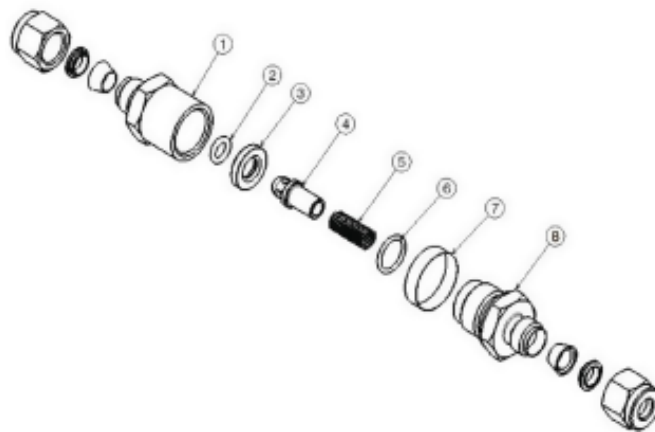

Item	Désignation	Designation	Beschreibung	Matière Material Werkstoff
1	Corps d'entrée	Inlet body	Eingangskörper	316 L
2	Siège	Seat	Sitz	FPM*
3	Support de siège	Seat stand	Sitzträger	316 L
4	Clapet	Valve	Klappe	316 L
5	Ressort	Spring	Feder	302
6	Etiquette couleur	Colored label	Farbetikette	PP
7	Joint torique	O-ring	O-ring	FPM*
8	Corps de sortie	Outlet body	Ausgangskörper	316 L

*For other materials, see the "Seal material" table.

SERIES AT300 - HIGH PRESSURE

DIMENSIONS

DIMENSIONS

ABMESSUNGEN

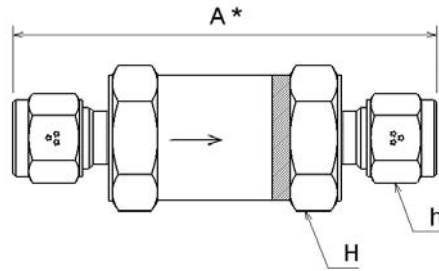

* Dimensions are measured with nuts in the finger tight position.

Part Number	Inlet - Outlet		Orifice size		A *		H		h	
	Inlet	Outlet	mm	inch	mm	inch	mm	inch	mm	inch
4S-AT300-*	1/4" Tube fittings	1/4" Tube fittings	4.5	0.18	62.5	2.46	19	0.75	14	0.55
4A-AT300-*	1/4" Tube adapter	1/4" Tube adapter	4.5	0.18	58.6	2.31	19	0.75		
4M-AT300-*	1/4" Male NPT	1/4" Male NPT	4.5	0.18	56	2.20	19	0.75		
4F-AT300-*	1/4" Female NPT	1/4" Female NPT	4.5	0.18	56	2.20	19	0.75		
4M4F-AT300-*	1/4" Male NPT	1/4" Female NPT	4.5	0.18	56	2.20	19	0.75		
4F4M-AT300-*	1/4" Female NPT	1/4" Male NPT	4.5	0.18	56	2.20	19	0.75		
4M4S-AT300-*	1/4" Male NPT	1/4" Tube fittings	4.5	0.18	60	2.36	19	0.75		
4MP-AT300-*	1/4" Male BSPP	1/4" Male BSPP	4.5	0.18	54	2.13	19	0.75		
4FP-AT300-*	1/4" Female BSPP	1/4" Female BSPP	4.5	0.18	47	1.85	19	0.75		
4MT-AT300-*	1/4" Male BSPT	1/4" Male BSPT	4.5	0.18	56	2.20	19	0.75		
4FT-AT300-*	1/4" Female BSPT	1/4" Female BSPT	4.5	0.18	56	2.20	19	0.75		
4V-AT300-*	1/4" Male Gazel®	1/4" Male Gazel®	4.5	0.18	58.5	2.30	19	0.75		
M6S-AT300-*	6mm Tube fittings	6mm Tube fittings	4	0.16	63.6	2.50	19	0.75	14	0.55

SERIES AT300 - HIGH PRESSURE

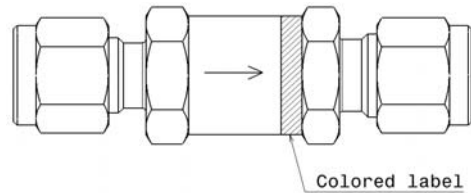

Cracking Pressure	Label Color		
	Blanc	White	Weiß
1/3 psi	Gris	Grey	Grau
1 psi	Jaune	Yellow	Gelb
2 psi	Orange	Orange	Orange
3 psi	Rose	Pink	Rosa
4 psi	Rouge	Red	Rot
10 psi	Brun	Brown	Braun
25 psi	Vert	Green	Grün
40 psi	Bleu	Blue	Blau
50 psi	Noir	Black	Schwartz

SERIES PG

DESCRIPTION

Les purges manuelles Sagana® sont utilisées pour purger des canalisations, cuves, vannes... La purge peut être fermée manuellement ou avec une clé. L'écrou de réglage est serti de façon à empêcher l'expulsion de celui-ci sous pression. Les purges Sagana® sont disponibles avec différents raccords.

DESCRIPTION

Sagana® manual purge valves are used to flush out pipe works, tanks, valves ... The purge valve can be closed manually or with a wrench. The adjusting nut is tightened so as to prevent expulsion under pressure. Sagana® purge valves are available with different connectors.

BESCHREIBUNG

Die manuellen Entlüftungsventile von Sagana® werden zum Ablassen von Kanalisationen, Wannen, Ventilen usw. eingesetzt. Das Entlüftungsventil kann manuell oder mit einem Schlüssel geschlossen werden. Die Stellmutter ist gequetscht, damit sie sich unter Druck nicht öffnet. Die Sagana® Entlüftungsventile sind mit verschiedenen Verbindungen lieferbar.

INFORMATIONS TECHNIQUES

TECHNICAL DATA

TECHNISCHE DATEN

Inox / Stainless steel / Rostfreier Stahl :
PN = 270 bar / 3916 psi

Laiton / Brass / Messing:
PN = 200 bar / 2900 psi

Air Cv= 0,04

NOMENCLATURE

PART LIST

NOMENKLATUR

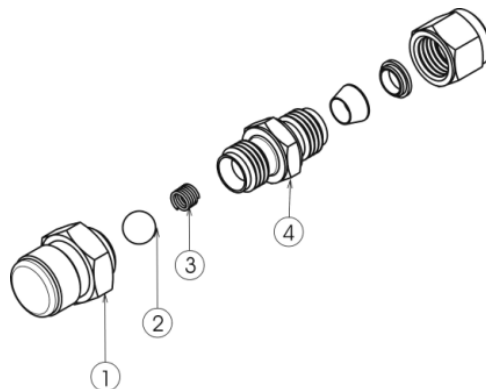

Item	Désignation	Designation	Beschreibung	Material	
				Stainless Steel	Brass
1	Ecrous	Cap	Schraubenmutter	316L Stainless Steel	Brass
2	Bille	Ball	Murmel	316L Stainless Steel *	
3	Ressort	Spring	Sprungfeder	302 Stainless Steel	
4	Corps	Body	Körper	316L Stainless Steel	Brass

SERIES PG

CONFIGURATIONS

CONFIGURATIONS

KONFIGURATIONEN

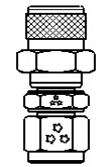

Straight

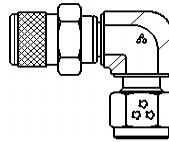

Elbow 90°

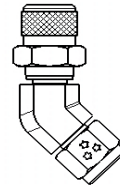

Elbow 45°

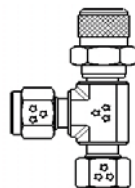

Tee 90°

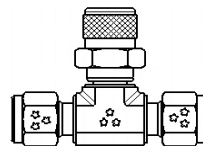

Inline Tee

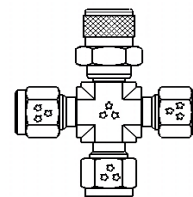

Cross

DIMENSIONS

DIMENSIONS

ABMESSUNGEN

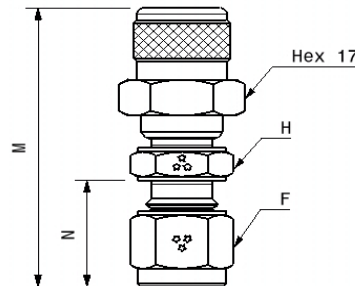

End Connections	Ref.	M*		N		H		F	
		mm	inch	mm	inch	mm	inch	(mm)	inch
1/8" Sagana® Tube fittings	2S	33.9	1.33	15.2	0.60	14	0.55	12	0.47
1/4" Sagana® Tube fittings	4S	36.3	1.43	17.8	0.70	14	0.55	14	0.55
3/8" Sagana® Tube fittings	6S	39.8	1.57	19.3	0.76	14	0.55	19	0.75
3mm Sagana® Tube fittings	M3S	33.9	1.33	15.3	0.60	14	0.55	12	0.47
6mm Sagana® Tube fittings	M6S	36.3	1.43	17.7	0.70	14	0.55	14	0.55
10mm Sagana® Tube fittings	M10S	39.8	1.57	19.5	0.77	14	0.55	19	0.75
1/8" Female NPT (BSPT, BSPP)	2F	26.6	1.05	9.5	0.37	14	0.55		
1/4" Female NPT (BSPT, BSPP)	4F	31.1	1.22	14.3	0.56	19	0.75		
3/8" Female NPT (BSPT, BSPP)	6F	32.9	1.30	14.3	0.56	22	0.87		
1/2" Female NPT (BSPT, BSPP)	8F	37.8	1.49	19.1	0.75	27	1.06		
1/8" Male NPT (BSPT, BSPP)	2M	28.1	1.11	9.5	0.37	14	0.55		
1/4" Male NPT (BSPT, BSPP)	4M	33.2	1.31	14.3	0.56	14	0.55		
3/8" Male NPT (BSPT, BSPP)	6M	33.7	1.33	14.3	0.56	19	0.75		
1/2" Male NPT (BSPT, BSPP)	8M	40	1.57	19.1	0.75	22	0.87		
1/8" Sagana® Tube adapter	2A	32.2	1.27	13.5	0.53	14	0.55		
1/4" Sagana® Tube adapter	4A	35	1.38	15.9	0.63	14	0.55		
3/8" Sagana® Tube adapter	6A	36	1.42	17.5	0.69	14	0.55		
3mm Sagana® Tube adapter	M3A	32.2	1.27	13.5	0.53	14	0.55		
6mm Sagana® Tube adapter	M6A	35	1.38	15.9	0.63	14	0.55		
10mm Sagana® Tube adapter	M10A	36	1.42	17.5	0.69	14	0.55		

* Dimensions measured with nut in the finger thigh position.

SERIES PG

**COMMENT
COMMANDER**

HOW TO ORDER

ZUM BESTELLEN

Example:

M6S - PG - E - SS

① ② ③ ④

Purge en coude 90° avec raccord
Sagana® double bague 6mm
Matière = AISI 316L



Purge valve in 90° bend with Sagana®
compression fittings 6mm connector
Material = AISI 316L

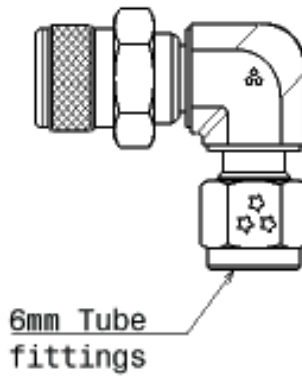

Entlüftungsventile mit 90° Krümmung
und 6mm Sagana®
Doppelringverschraubung.
Material = AISI 316L



End connections	Purge	Model	Material	Ball	Thread
①	②	③	④	⑤	⑥
2S, 4S, 6S M3S, M6S, M10S 2F, 4F, 6F, 8F 2M, 4M, 6M, 8M 2FA, 4FA, 6FA M3FA, M6FA, M10FA	PG	S - Straight J - 45° Elbow E - 90° Elbow T - Inline tee TU - Angle Tee C - Union	SS - Stainless steel B - Brass	P - PTFE 316L*	BSPP Thread BSPT Thread

*316L is the standard, you don't have to specify it

★ ★★				
	1 bar	=	14,51 PSI	= 100 kPa.
	1 PSI	=	.069 bar	= 6,89 kPa
	1 kPa (ISO)	=	.01 bar	= .1451 PSI
	1 Kg/cm ²	=	.980 bar	= 14.22 PSI = 98 kPa
	T°C (C : Celsius)	=	(T°F - 32) / 1.8	= T°K - 273.16
	T°F (F : Farenheit)	=	(1.8 x T°C) + 32	= (1.8 x T°K) + 523.69
	T°K (K : Kelvin)	=	T°C + 273.16	= (T°F / 1.8) + 255,38
	T°R (R : Rankine)	=	(1.8 x T°C) + 491.69	= T°F + 459.69
	1 inch	=	25.4 mm	
	1 mm	=	0.045 inch	

★ ★★	Normes Filetage	Norms Thread	Normen Gewinde
	Conique (ISO 7/1)	Tapered (ISO 7/1)	Konisch (ISO 7/1)
	NPT (Briggs) : NFE 03-601 BSPT (Whitw orth) : NFE 03-004	NPT (Briggs): BS 21 (1968) BSPT (Whitw orth): BS 21 (1973)	NPT (Briggs): / BSPT (Whitw orth): DIN 2999
	Parallèle (ISO228/1)	Parallel (ISO228/1)	Parallel (ISO228/1)
	BSPP (Whitw orth) : NFE 03-005	BSPP (Whitw orth): BS 2779 (1973)	BSPP (Whitw orth): DIN 3852

★ ★★	Classes de pression des filetages - Laiton	Thread pressure ratings - Brass	Klassifizierung - Messing
---------	-----------------------------------------------	------------------------------------	------------------------------

FILETAGE MÂLE - MALE THREAD - AUSSENGEWINDE							
F	1/8"	1/4"	3/8"	1/2"	3/4"	1"	
Bar⇒	345	276	269	262	248	179	
PSI⇒	5000	4000	3900	3800	3600	2600	

FILETAGE FEMELLE - FEMALE THREAD - INNENGEWINDE							
F	1/8"	1/4"	3/8"	1/2"	3/4"	1"	
Bar⇒	221	227	179	165	159	152	
PSI⇒	3200	3300	2600	2400	2300	2200	

★ ★★	Classes de pression des filetages - Acier Inox 316L	Thread pressure ratings - Stainless Steel 316L	Klassifizierung - 316L
---------	--------------------------------------------------------	---------------------------------------------------	---------------------------

FILETAGE MÂLE - MALE THREAD - AUSSENGEWINDE							
F	1/8"	1/4"	3/8"	1/2"	3/4"	1"	
Bar⇒	648	517	503	496	469	345	
PSI⇒	9400	7500	7300	7200	6800	5000	

FILETAGE FEMELLE - FEMALE THREAD - INNENGEWINDE							
F	1/8"	1/4"	3/8"	1/2"	3/4"	1"	
Bar⇒	420	427	345	317	296	283	
PSI⇒	6100	6200	5000	4600	4300	4100	

e-mail: info@sagana.rotarex.com

website: www.rotarex.com



Headquarters Luxembourg



information